



# Arts & Crafts

# TOOL CABINET

The goal: The maximum tools in the minimum space.

Sometime while sawing the 60th dovetail for a drawer side, when my patience was as thin as the veneer facing on cheap plywood, a familiar feeling crept into my body. I began to experience an understandable lust for my biscuit joiner.

It sat patiently on a shelf, and I knew that its chattering, rattling teeth would make everything about this tool cabinet go much faster. But I resisted, because I had the words of a Victorian social reformer, art critic and part-time madman ringing in my head.

The writings of Englishman John Ruskin (1819-1900) were a cornerstone of the American Arts & Crafts movement. Ruskin decried the worst parts of 19th century industrialism. He promoted craft, pensions and public education when there was little of those things for the poor.

And in his book the “Seven Lamps of Architecture, The Lamp of Memory,” which was published in 1849, he wrote a passage that all woodworkers should read. It’s a bit long and a bit dramatic, but it has stuck with me just the same.

“When we build, let us think that we build forever. Let it not be for present delight nor for present use alone. Let it be such work as our descendants will thank us for; and let us think, as we lay stone on stone, that a time is to come when those stones will be held sacred because our hands have touched them, and that men will say, as they look upon the labor and wrought substance on them, ‘See! This our father did for us.’”

The biscuit joiner stayed on

the shelf. I continued to saw, chop, pare and fit for another four or five hours. Ruskin, I hoped, would have approved.

## From the Book of Tolpin

While Ruskin kept me going through this long and difficult project, I really have a 20th century craftsman and author to thank (or blame) for my obsession with building a fine tool cabinet. Since it was first published in 1995, “The Toolbox Book” (Taunton Press) by Jim Tolpin has become the most-thumbed book in my library. I’ve studied every page, toolbox and drawing between its maroon cover boards (the dust jacket is long gone).

Years ago, I resolved to build

myself a cabinet that might rival some of the examples in “The Toolbox Book.” This year, I gave it my best shot. Since early 2004 I’ve spent many spare moments doodling on graph paper and on my computer to come up with a design that satisfied the three things I wanted from a cabinet: It had to hold a lot of tools, look good and be built to last. After studying my work habits, measuring all my tools and paging through thousands of examples of Arts & Crafts casework, this is what I came up with.

It’s small but spacious. Have you ever ridden in an old Volkswagen Beetle? They are surprisingly roomy, and especially generous with the headroom. Somehow, the Beetle violates the laws of space and physics, and it is roomy but can also be parked between two oversized Hummers. This cabinet

*continued on page 70*

by Christopher Schwarz

*Comments or questions? Contact Chris at 513-531-2690 ext. 1407 or  
chris.schwarz@fwpubs.com.*

## 6 STORAGE SOLUTIONS

Tools need to be protected, organized and easily retrieved. That's a tall order.

Here are some of the problems I've run into over the years: Hanging tools on a wall keeps them organized and close at hand, but unprotected. Keeping them in a traditional sliding tool till in a chest keeps them protected and organized, but you dig around for them endlessly. Drawers under a bench keep them protected and close at hand, but most drawers end up a jumbled mess.

Here's my solution, and so far it works well. The cubbyholes are sized exactly to hold a full complement of hand planes. Finding the right plane and getting it down for use has never been easier.

The chisel rack puts my most-used sizes out where I can get them. And the rack is designed to hold the tools even when the door is accidentally slammed.

The saw till on the right door is the same way. These two saws do 80 percent of my work and they're always handy.

The real feature is the drawers. The smaller drawers hold tools for a specific operation. In the larger drawers, the interchangeable trays stack inside the drawers and also hold tools for a specific operation. Whenever I dovetail, I grab the top right drawer. No more making mounds of tools on the bench.

### Chisel Rack

This simple L-shaped bracket holds the five chisels I use most, plus my drawbore pins. Don't use a magnetic strip; it will magnetize your tools, which makes them difficult to sharpen.



### Tool Trays, Lower Drawer

The bottom of the drawer is for the tools I rarely need. The tray at left holds files and rasps (I'm going to subdivide this tray as soon as some more rasps arrive in the mail). The tray at right holds specialty chisels and screwdrivers.



### Top Shelf Plane Cubby

This area isn't just what's left over from the remainder of the cabinet. It is carefully sized at 22½" wide x 5¾" high to hold a No. 7 jointer plane (a constant companion in my shop), plus a jack plane, a panel plane and scraper plane.



### Small Plane Cubbies

The cubbyholes are a magic size: 6¼" high, about 3⅝" wide and 10½" deep. This size holds all my joinery planes, my scrub plane, smoothing planes and miter plane.

### Saw Till

My saw till holds the two most useful joinery saws – a dovetail saw and a carcass saw. My full-size saws reside on pegs below the cabinet.



### Four Upper Drawers

Each of the four drawers holds all the tools for a common operation: one is for dovetailing, the second is for trimming and squaring assemblies, the third is for marking and measuring, and the fourth is for nailing and screwing.



### Tool Tray, Middle Drawer

The lower section of the drawer holds waterstones and honing guides (make sure the stones are bone dry before putting them back in the drawer). The tray shown above holds my four spokeshaves and some specialty sharpening equipment.



continued from page 67

is designed to function the same way. The interior is a mere 11 $\frac{1}{4}$ "-deep, 22 $\frac{1}{2}$ " wide and 31 $\frac{1}{2}$ " tall. Yet, thanks to good planning, it holds every hand tool I need.

The cubbyholes and shelf for hand planes are carefully sized for all the planes needed in a modern shop. The drawers are loaded with trays of tools. Each tray contains all the tools for a routine function, such as dovetailing, sharpening or shaping curved surfaces.

The cabinet looks pretty good. I spent months thumbing through old Art & Crafts furniture catalogs and contemporary hardware catalogs for inspiration. This cabinet and its lines are a little bit

Gustav Stickley, a little Harvey Ellis and a little of myself.

The cabinet will endure. No compromises were made in selecting the joints. Every major component (with the exception of the changeable, nailed-together trays) are built to withstand heavy use. Of course, when you discuss durable joints, you are usually talking dovetails, which is where we'll begin construction.

### A Case that Takes a Beating

When this cabinet is fully loaded, my best guess is that it weighs more than any single member of our staff at the magazine (modesty prevents me from revealing

what that upper limit might be). To ensure the bottom and top pieces can withstand this weight, I joined them to the side pieces with through-dovetails.

One interesting variation worth noting here is that instead of using one solid top piece, I substituted two 3"-wide rails and dovetailed them into the sides to save a little weight. Because I cut these dovetails by hand, it was simple to lay out this unusual arrangement. If you plan to use a dovetail jig, you will save yourself a headache by forgetting the rails and making your top one solid piece instead.

If you're cutting the dovetails by hand, it's faster and more

accurate to clamp your two sides together and saw the tails on the side pieces simultaneously. For years I resisted this technique because it seemed more difficult, but now I know better.

A second feature of the case to note is that the rabbet for the back is a hefty 1" wide. This allows room for the  $\frac{1}{2}$ "-thick shiplapped back, plus a  $\frac{1}{2}$ "-thick French cleat that will park the cabinet on the wall and keep it there.

And then there are the stopped dados. These  $\frac{1}{4}$ "-deep joints in the side pieces hold all the dividers. Cutting these joints is simple work with three tools: a plunge router, a bearing-guided straight



When sawing the tails, clamp the two sides together and cut them at the same time. This saves time and effort and prevents layout errors.



If your rabbets for the back are perfectly square, your case is much more likely to end up square, too. Clean up any imperfections with a rabbeting plane, such as this bullnose rabbet plane.



The shop-made T-square jig and a plunge router make quick work of the dados.

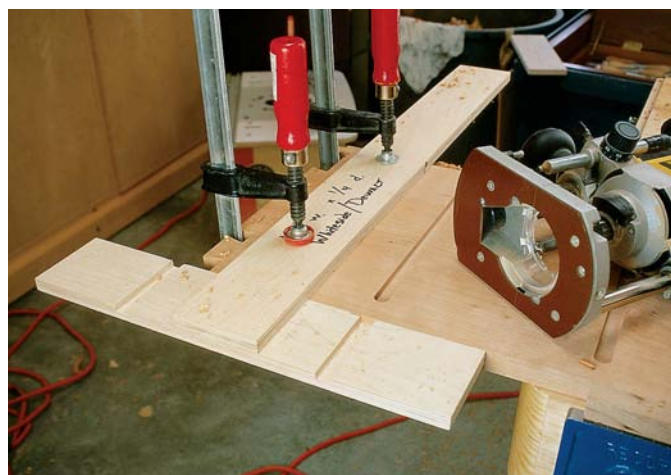

Here you can see how you use the dado cut into the jig to line up the jig with your layout lines. Using a router with a flat side on its base is more accurate than using a router with a round base.

bit and a shop-made T-square jig that guides the whole shebang. Lay out all the locations of your dados on the sides. Park the jig so it lines up with your layout lines. Cut the dados in two passes.

Fitting all the horizontal dividers to fit the dados is easy. The 1/2"-thick dividers simply need a small notch at the front to fit over the rounded end of the dado created by the round straight bit. A sharp backsaw is just the tool here.

The 3/4"-thick horizontal divider needs a bit more work to fit in the 1/2"-wide dado. A 1/4" x 1/4" end-rabbit is the answer.

The through-dados that hold the vertical dividers use the same

router jig, but with the plunge router set to make only an 1/8"-deep cut. Laying out the locations of these parts for the hand plane cubbyholes might seem daunting. If you want the openings evenly spaced, they should each be 3.333" wide. I don't have any infinite numbers on my ruler. But it's actually child's play to lay out the cubbyholes with a pair of dividers (they look like a school compass but with two pointy tips – no pencil). You can tweak these tools until they step off the cubbyholes as precisely as you please. Dividers are one of my secret weapons.

With all these parts cut and fit, make the back of the case. I used

ambrosia maple. It's cheap and looks a bit like the spalted maple I used in the doors and drawers. The back boards are joined by a 1/4"-deep x 3/8"-wide shiplap on each long edge.

The top cap is easy. Cut the wide chamfer on the underside using your table saw. Clean up the cut with a block plane. Attach the top to the rails with screws.

You are now at a critical juncture. You can go ahead and get some quick gratification and assemble the whole case. But good luck when you go to finish it. Getting those cubbyholes finished right will be murder. The better solution is to glue up only

the sides, bottom and top rails. Tape off the exposed joints and finish all the case parts (I used two coats of a satin spray lacquer). Then assemble the case. I know it sounds like a pain (it is). But the end result is worth it.

Finish the back pieces and top cap while you're at it. Now you can screw the back in place and the top cap. You are ready for the doors and drawers.

### Easier than They Look

The doors aren't too bad. The mullions and muntins that form the four lights in each door appear difficult, but thanks to a little leg-erdmain, it's no problem.



Fitting the dividers is easy with a hand plane. I merely make sure the dividers are surfaced a few thousandths of an inch thicker than where I want them to be. Then I thin them down with a smoothing plane until they slide in with just a little persuasion.



After gluing the sides to the bottom and top rails, trim the dovetails flush with a block plane. Soak the end grain with a little bit of mineral spirits to make it easier to cut. Here you can also see how I supported the case as I worked on it. The big slab holding up the side is an offcut from an old door that's clamped to my bench.



Cut the rabbet on the backside of the door using a rabbeting bit in your router table. With a large tabletop such as this, it's simple work.



Glue one backing strip into the rabbet in the door on edge. Then flip the door over and glue a mullion onto the backing strip. Then use spring clamps to hold everything while the glue dries.



Install the horizontal muntins the same way. First glue a backing strip into the rabbet on the backside of the door. Then flip the door over and glue the muntin to that.

But before getting mired in those details, you need to assemble the doors. Here's how they work: The stiles and rails are joined using mortise-and-tenon joints. For mid-size doors such as these, I use  $\frac{3}{8}$ "-thick x 1"-long tenons.

Cut your tenons and your mortises, then mill a  $\frac{1}{4}$ "-wide x  $\frac{3}{8}$ "-deep groove in the rails and stiles to hold the door panel. I generally make this groove on the rou-

er table using a straight bit and featherboards. It's the easiest way to make the groove start and stop in the right place in the stiles.

The door panel needs a rabbet on its back to fit in the groove. But before you mill the panel, you should know a bit about spalted maple. Its black spidery lines are caused by the spalt fungus, which attacks the tree after it's been felled. In short, it's partly rotted.

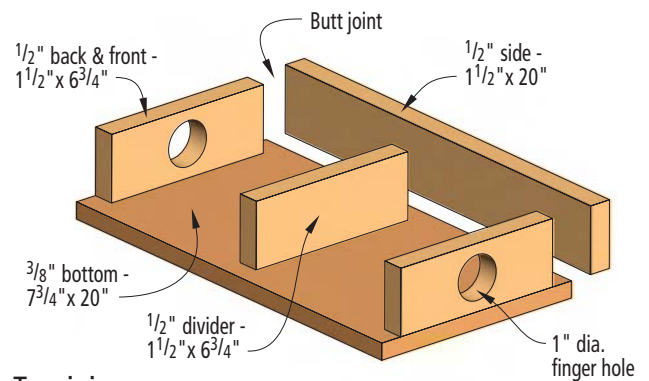

### Tray joinery

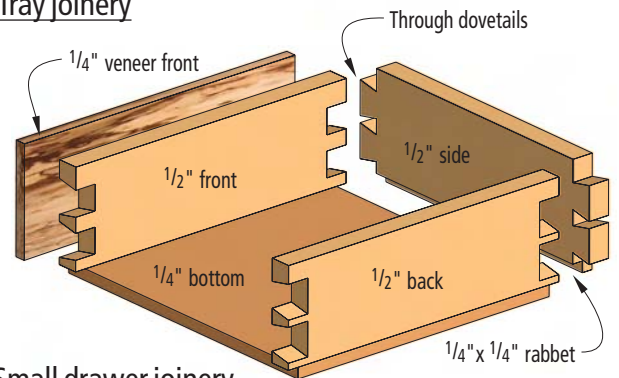

### Small drawer joinery

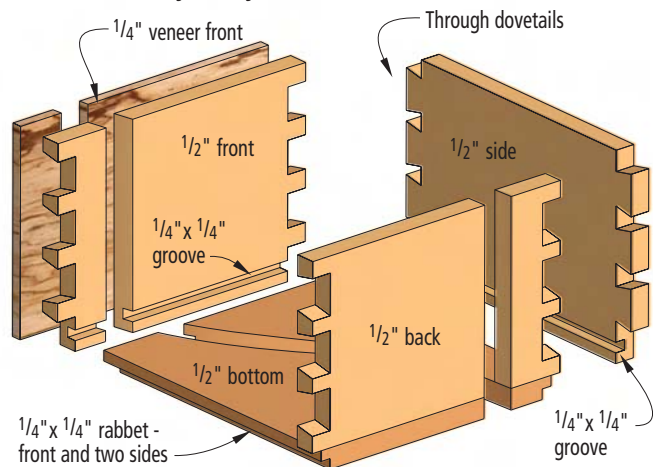

### Large drawer joinery

It's always best to wear a respirator when dealing with spalted wood. There are numerous accounts of people who have had respiratory problems after breathing in the dust.

Once you fit the panel, assemble the doors – the mullions and muntins are added after assembly. Once the glue cures, cut a 1/4"-wide x 1/2"-deep rabbet on the backside of the opening for the glass. This rabbet will hold the narrow backing strips that are built up into the mullions and muntins.

This technique was explained fully by Glen Huey in our August 2002 issue ("Simple Divided-light Glass Doors"). But the photos at left explain it better than words can. Essentially, you create the T-shaped moulding that makes the mullions and muntins by gluing together 1/4"-thick x 1/2"-wide strips of wood. It's simple work.

What's not so simple is mounting the doors with the strap hinges. These hinges are inexpensive, beautiful and handmade. As a result, they need a bit of tweak-

ing and bending and hammering and cursing to get them just right to hang a door.

Here's my best tip: Screw the hinges in place with the cabinet on its back. Then stand it up, loosen the hinge screws and make your final adjustments. I used a block plane to make some adjustments, and a mallet for others. Let your frustration level be your guide.

### Getting a Handle on Drawers

The drawers are a long slog. Even though I'm a fair dovetailer, it took

me three solid days of work to get the drawers assembled and fit. But before you start listening to that lock-miter router bit whispering in your ear, remember this: The drawers are going to hold a tremendous amount of steel. And when you open the drawers during a future project, you'll never be disappointed to see dovetails.

To make things a tad easier, I built all the drawers using through-dovetails and 1/2"-thick material for the front, sides and back. Then, with the drawer glued up, I glued on a 1/4"-thick piece of spalted maple to the front piece. This trick also allowed me to stretch my supply of spalted maple.

The four small drawers are built a little differently than the two larger ones. Because the small drawers are shallow, I wanted to use every bit of space. So the bottom is 1/4"-thick plywood that's nailed into a 1/4" x 1/4" rabbet on the drawer's underside.

The larger drawers are more conventional. Plow a 1/4" x 1/4" groove in the sides and front pieces to hold a 1/2"-thick bottom, which is rabbeted to fit in the groove.

Build all the drawers to fit their openings exactly, then use a jack plane to shave the sides until the drawer slides like a piston. Finish the doors and drawers, then it's

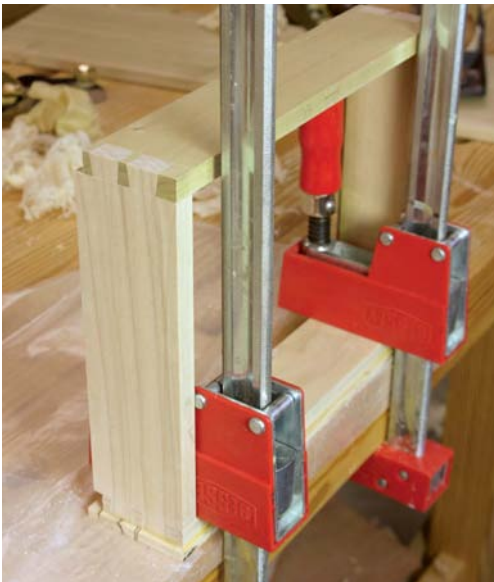

Build the drawers with through-dovetails. Then glue a piece of 1/4"-thick veneer to the front.



Here you can see the two different ways of installing the drawer bottoms. The bottom in the top drawer rests in a rabbet in the sides. The drawer bottom for the larger drawers slides into a groove.



Install the dividers in the drawers so they can be easily removed in the future. A 23-gauge pinner is an excellent tool for this job.



Once everything is finished, install the glass using small strips of cherry (1/8" and 1/4" thick). A few dabs of clear silicone and a couple small pins do the trick.



time for the fun part: dividing up the drawers, building trays for the tools and tweaking the hardware so everything works just right.

As you divide up the drawers and trays, one word of advice: Don't fasten any of the dividers permanently. Your tool set will change, and you want to be able to easily alter the dividers. I fit mine in place with friction and a couple 23-gauge headless pins. The divid-

ers can be wrenched free when I need room for a new tool.

When you hang the cabinet, use wide cleats—mine were each 5" wide. This allows you to get more screws into the cabinet and into the studs. Also, for extra insurance, I rested the bottom of the cabinet on a 2"-wide ledger that also was screwed into the studs.

With the project complete, the voice of Ruskin was final-

ly silenced for a short time as I assessed my work. (I for one was happy for the silence; Ruskin vacillated between madness and lucidity during the last years of his life.) I scolded myself for a few things: the reveals around the drawers on the left edge of the cabinet are a tad wider than the reveals on the right side. And in a couple of the dovetails at the rear of the drawers, there are a couple

small gaps. It's not perfect.

But before I got too down on myself, I remembered one more quote from Ruskin that relates to handwork and the pursuit of perfection. This one deserves as much ink as the first.

"No good work whatever can be perfect," he writes, "and the demand for perfection is always a sign of a misunderstanding of the ends of art." **PW**

## ARTS & CRAFTS TOOL CABINET

NO.	ITEM	DIMENSIONS (INCHES)			MATERIAL	COMMENTS
		T	W	L		
<b>Carcase</b>						
□ 2	Sides	3/4	12 1/4	33	Cherry	3/8" -deep x 1" -wide rabbet at back
□ 2	Top rails	3/4	3	24	Cherry	Dovetailed into sides
□ 1	Bottom	3/4	11 1/4	24	Cherry	Dovetailed into sides
□ 1	Top cap	1	17	32	Cherry	1/2" -deep x 3" -wide bevel
□	Shiplapped back	1/2	23 1/4	33	Maple	1/4" x 1/4" shiplaps
□ 1	Major horizontal divider	3/4	10 1/2	23	Cherry	In 1/4" -deep x 1/2" -wide dados
□ 1	Thin horizontal divider	1/2	10 1/2	23	Cherry	In 1/4" -deep x 1/2" -wide dados
□ 3	Thin horizontal dividers	1/2	9 1/4	23	Cherry	In 1/4" -deep x 1/2" -wide dados
□ 5	Vertical dividers	1/2	10	6 1/2	Cherry	In 1/8" -deep x 1/2" -wide dados
□ 2	Small vertical dividers	1/2	9 1/4	2 3/4	Cherry	In 1/8" -deep x 1/2" -wide dados
<b>Doors</b>						
□ 2	Large stiles	3/4	2 3/4	33	Cherry	
□ 2	Small stiles	3/4	1 1/4	33	Cherry	
□ 2	Top rails	3/4	2 3/4	10	Cherry	1" TBE
□ 2	Intermediate rails	3/4	2 1/4	10	Cherry	1" TBE
□ 2	Lower rails	3/4	3 3/4	10	Cherry	1" TBE
□ 2	Panels	1/2	8 1/2	16 3/4	Maple	In 1/4" -wide x 3/8" -deep groove
□ 2	Vertical muntins	1/4	1/2	8	Cherry	
□ 4	Horizontal muntins	1/4	1/2	3 3/4	Cherry	
□ 2	Backing strips	1/4	1/2	8 1/2	Cherry	In 1/4" -wide x 1/2" -deep rabbet, glued to vertical muntin
□ 4	Small backing strips	1/4	1/2	4 1/8	Cherry	Glued to horizontal muntin
<b>Drawers</b>						
□ 4	Small drawer fronts	3/4*	2 1/2	11	Maple	1/4" -deep x 1/2" rabbet on bottom edge
□ 8	Small drawer sides	1/2	2 1/2	9	Poplar	1/4" -deep x 1/4" rabbet on bottom edge
□ 4	Small drawer backs	1/2	2 1/4	11	Poplar	
□ 4	Small drawer bottoms	1/4	10 1/2	9	Plywood	Screwed to drawer box
□ 1	Medium drawer front	3/4*	5	22 1/2	Maple	1/4" -deep x 1/4" -wide groove for bottom
□ 2	Medium drawer sides	1/2	5	9	Poplar	1/4" -deep x 1/4" -wide groove for bottom
□ 1	Medium drawer back	1/2	4 1/2	22 1/2	Poplar	
□ 1	Medium drawer bottom	1/2	8 3/4	22	Plywood	1/4" -deep x 1/2" rabbet on bottom edge
□ 1	Large drawer front	3/4*	6 3/4	22 1/2	Maple	1/4" -deep x 1/4" -wide groove for bottom
□ 2	Large drawer sides	1/2	6 3/4	9	Poplar	1/4" -deep x 1/4" -wide groove for bottom
□ 1	Large drawer back	1/2	6 1/2	22 1/2	Poplar	
□ 1	Large drawer bottom	1/2	8 3/4	22	Plywood	1/4" -deep x 1/2" rabbet on bottom edge

\* Finished dimension, laminated from two pieces of wood; TBE= tenon, both ends

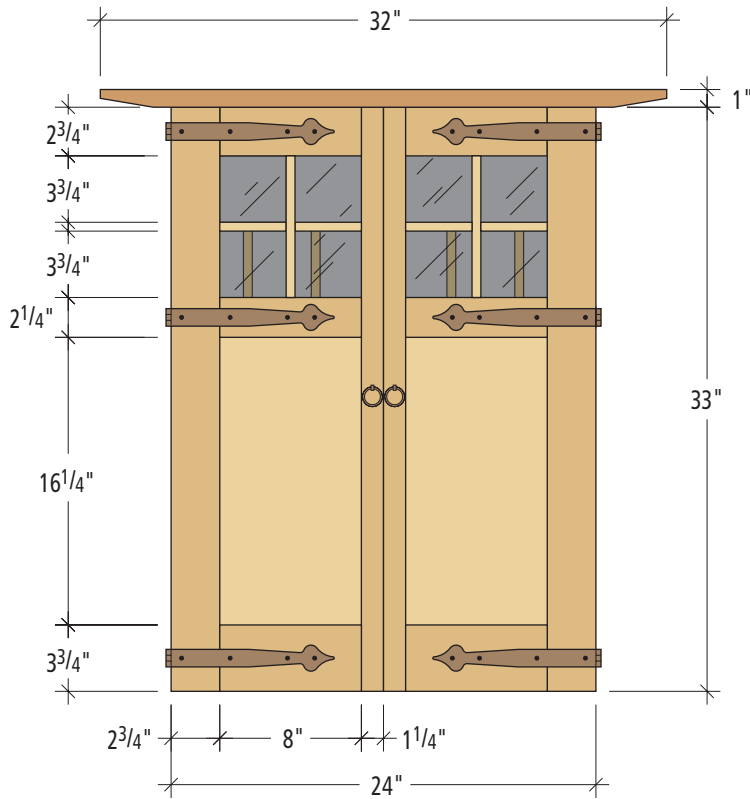

Elevation - doors closed

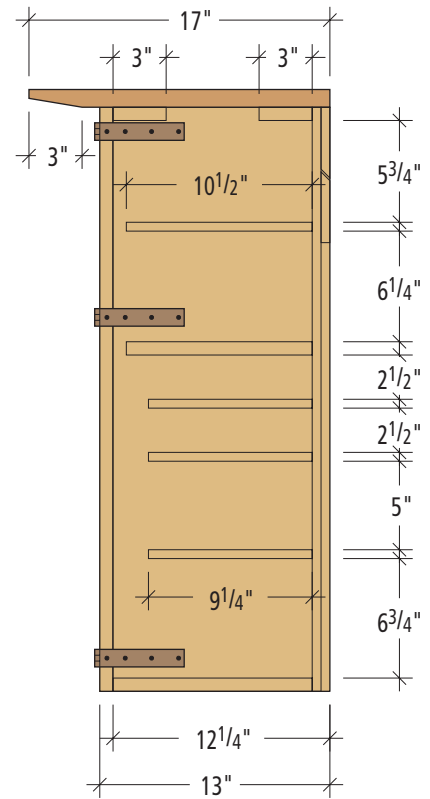

Profile

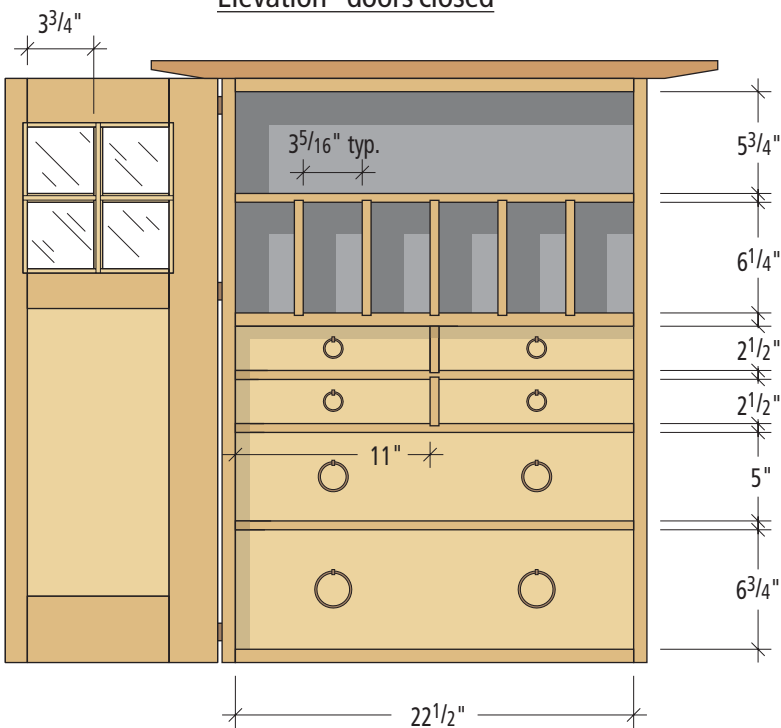

Elevation - doors open

## SUPPLIES

### Lee Valley Tools

800-871-8158 or [leevalley.com](http://leevalley.com)

- 6 • 28mm ring pulls, 01A61.28, \$1.65 each
- 2 • 40mm ring pulls, 01A61.40, \$2.45 each
- 2 • 50mm ring pulls, 01A61.50, \$3.10 each
- 6 • Unequal strap hinges, 9 1/2" x 5", 01H21.39, \$8.60 each
- 4 • Magnetic catches, 00S16.01, \$1.15 each
- 7 • #6 x 5/8" black pyramid-head screws (bags of 10), 01X38.65, \$1.40 a bag

Prices as of publication date.